

PONENTE CS/4098  
 CARTESIO CS/4111  
 ICARO CS/4114

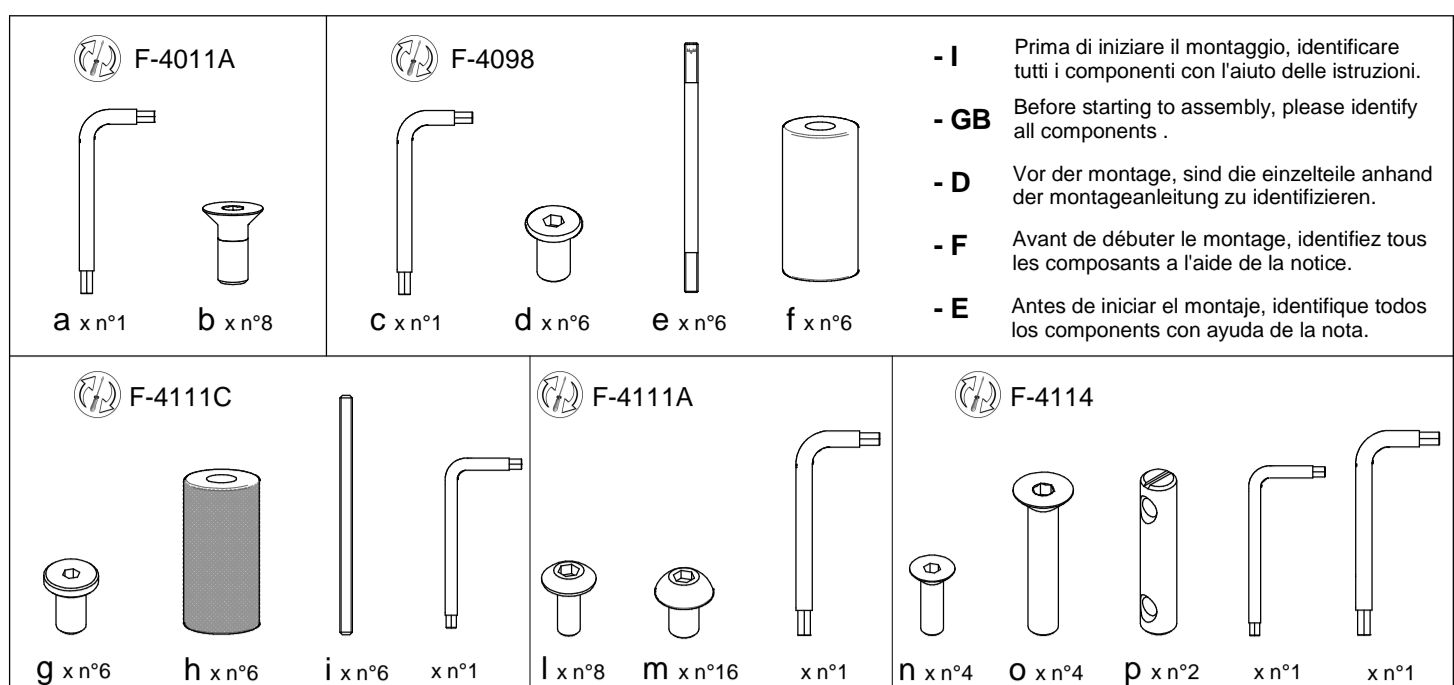

H-A 4098 02 00-3

**Attenzione-Attention-Vorsicht-Attention-Atención**

- I Si consiglia di effettuare il montaggio su una superficie morbida.
- GB It is a good idea to use a soft protective underlay during assembly.
- D Möbelteile auf eine weiche Oberfläche legen und dann aufstellen.
- F Veuillez poser les pièces sur un surface souple pour l'assemblage.
- E Se aconseja efectuar el montaje sobre una superficie blanda.

COMPANY WITH  
 MANAGEMENT SYSTEM  
 CERTIFIED BY DNV  
 ISO 9001 • ISO 14001



Calligaris S.p.A.  
 Via Trieste, 12  
 33044 Manzano - (UD) Italy  
 Tel. +39 0432 748211  
 calligaris.com

- I Pezzo di ricambio.
- GB Spare part.
- D Ersatzteil.
- F Pièce en échange / s.a.v.
- E Repuesto

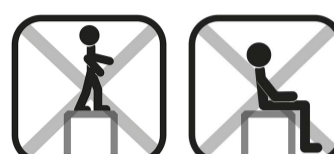

Copyright © Calligaris S.p.a. - Tutti i diritti riservati - All right reserved

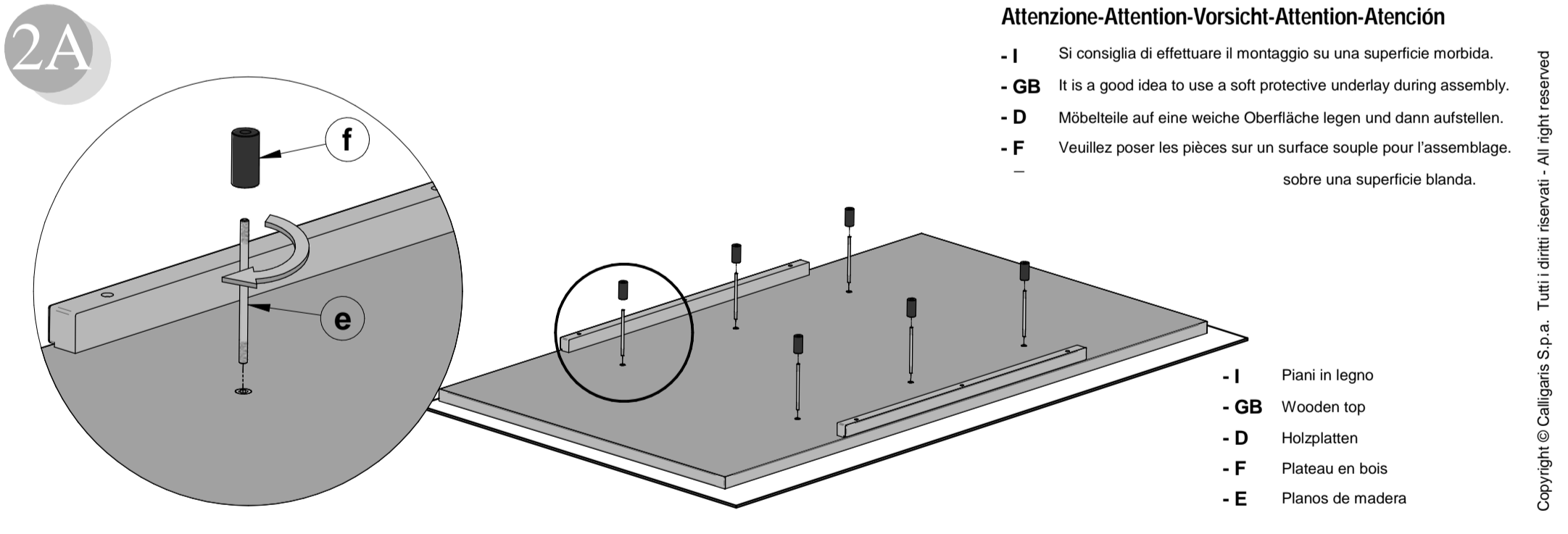
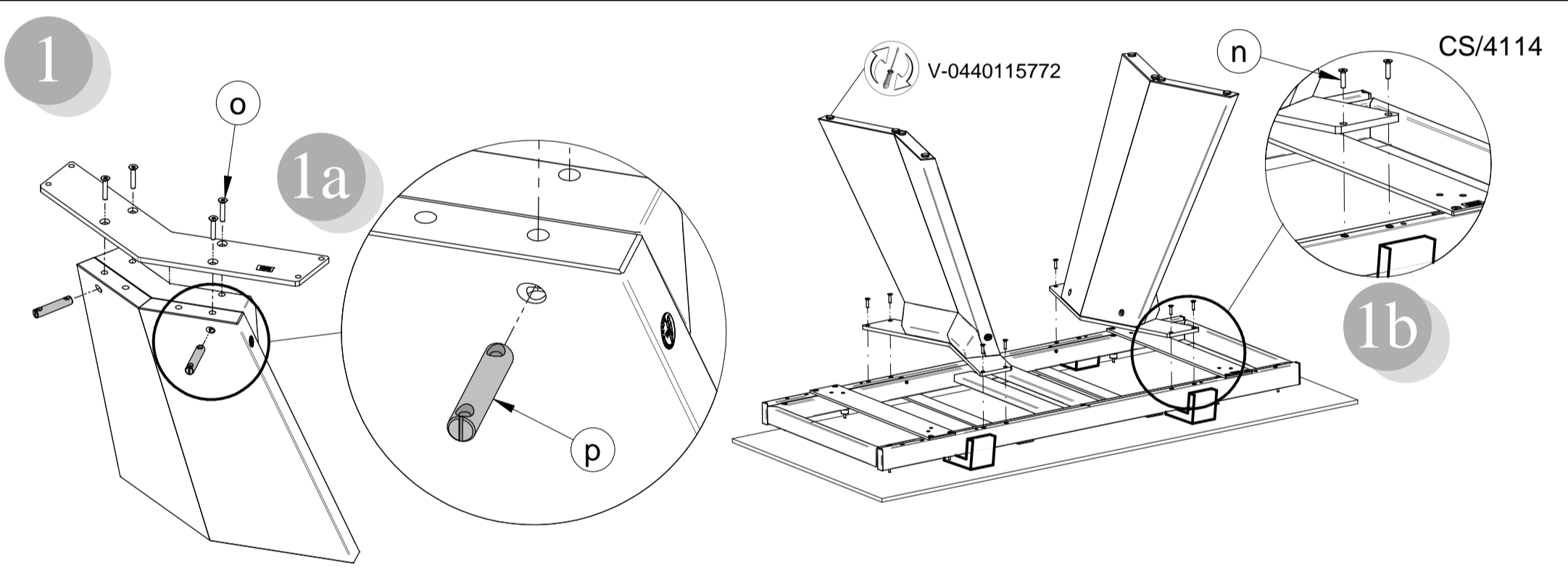
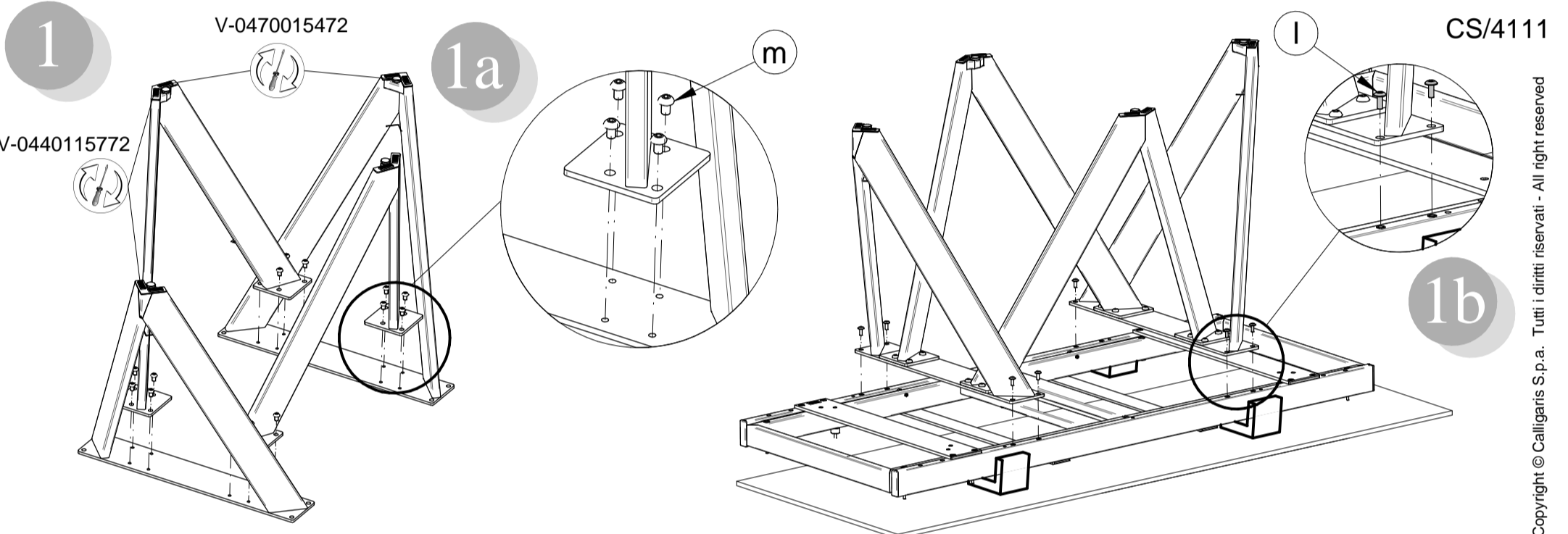
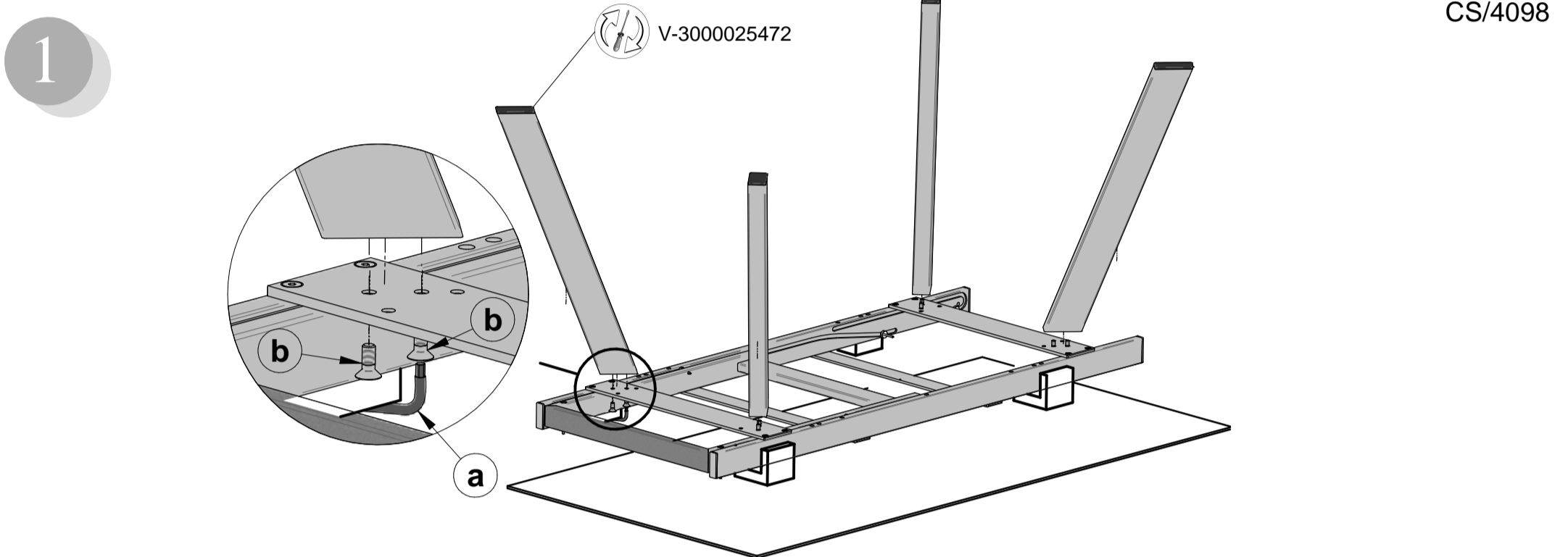

**Attenzione-Attention-Vorsicht-Attention-Atención**

- I Si consiglia di effettuare il montaggio su una superficie morbida.
- GB It is a good idea to use a soft protective underlay during assembly.
- D Möbelteile auf eine weiche Oberfläche legen und dann aufstellen.
- F Veuillez poser les pièces sur un surface souple pour l'assemblage.
- E Se aconseja efectuar el montaje sobre una superficie blanda.

- I Piani in legno
- GB Wooden top
- D Holzplatten
- F Plateau en bois
- E Planos de madera

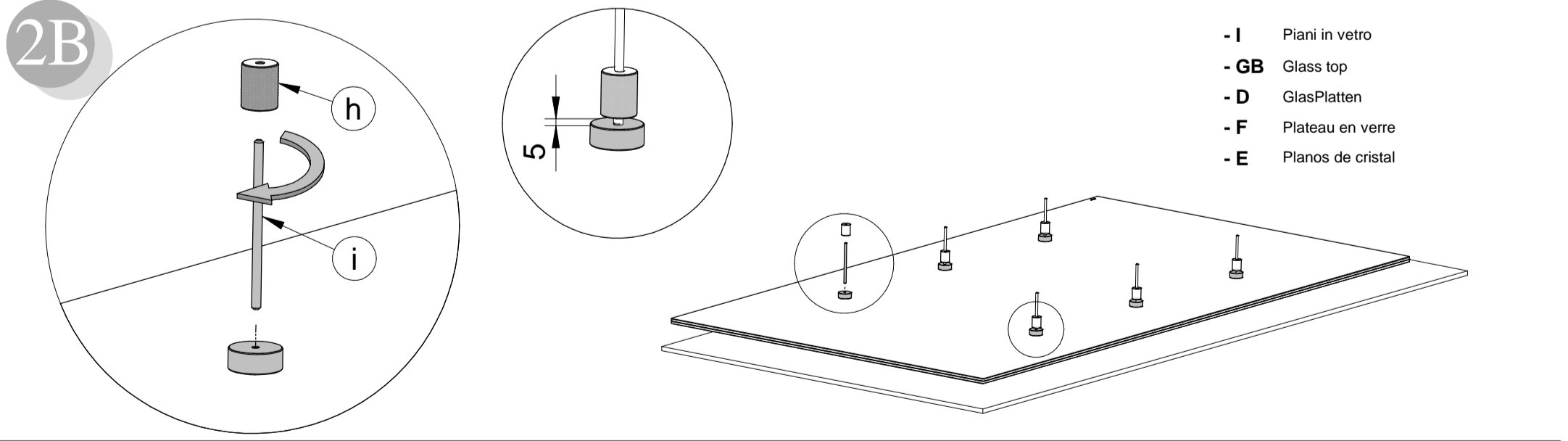

- I Piani in vetro
- GB Glass top
- D Glasplatten
- F Plateau en verre
- E Planos de cristal

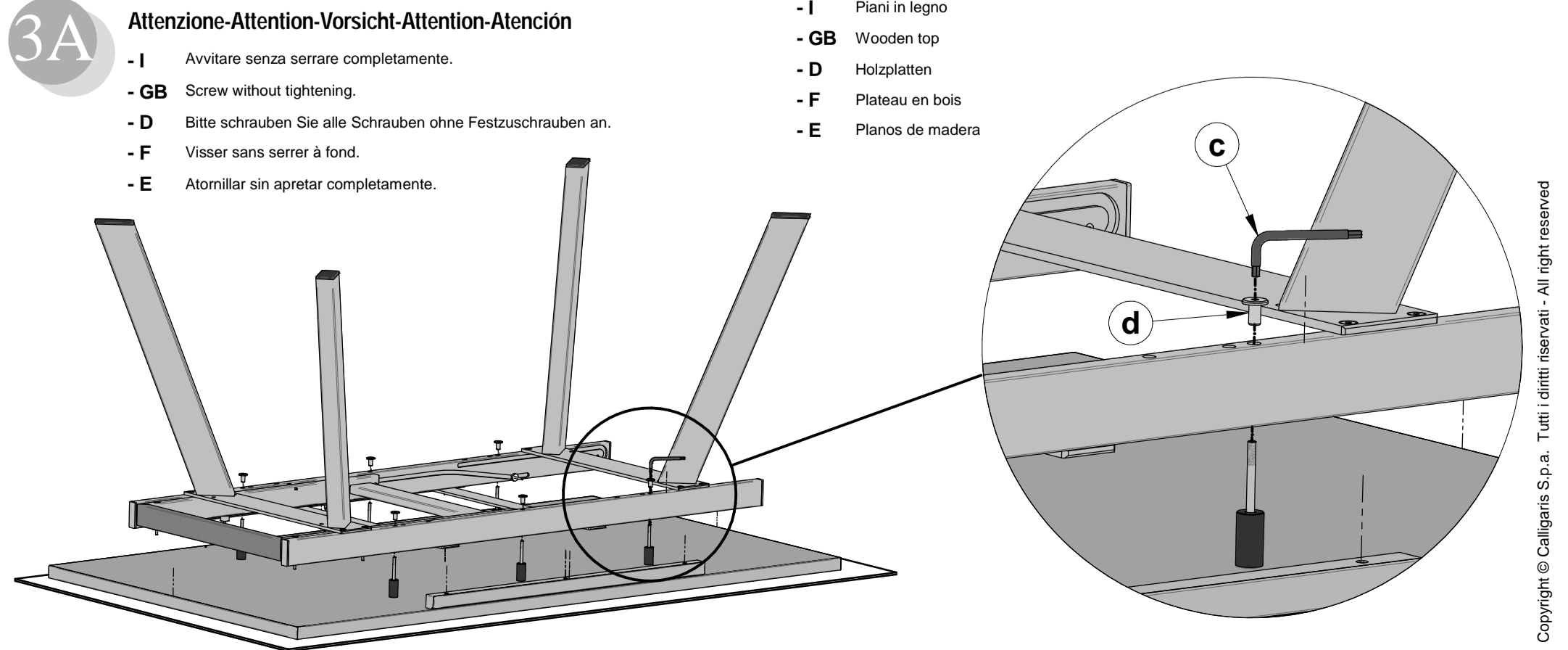

- Attenzione-Attention-Vorsicht-Attention-Atención**
- I Avvitare senza serrare completamente.
  - GB Screw without tightening.
  - D Bitte schrauben Sie alle Schrauben ohne Festzuschrauben an.
  - F Visser sans serrer à fond.
  - E Atornillar sin apretar completamente.

- I Piani in legno
- GB Wooden top
- D Holzplatten
- F Plateau en bois
- E Planos de madera

Copyright © Calligaris S.p.a. - Tutti i diritti riservati - All right reserved

3B

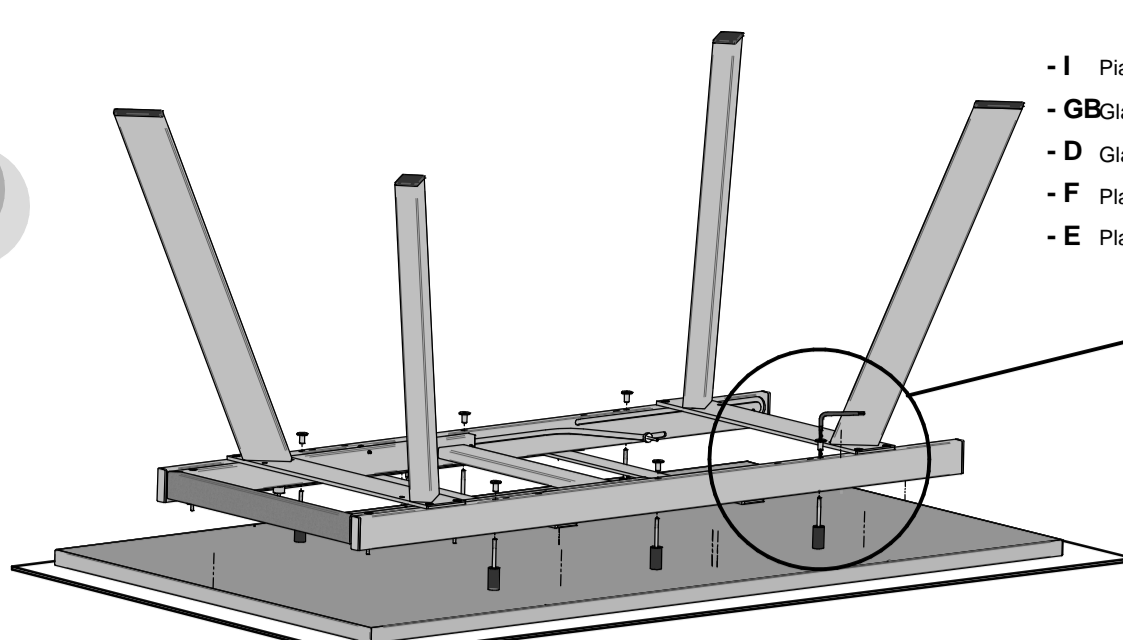

- I Piani in vetro
- GB Glass top
- D Glasplatten
- F Plateau en verre
- E Planos de cristal

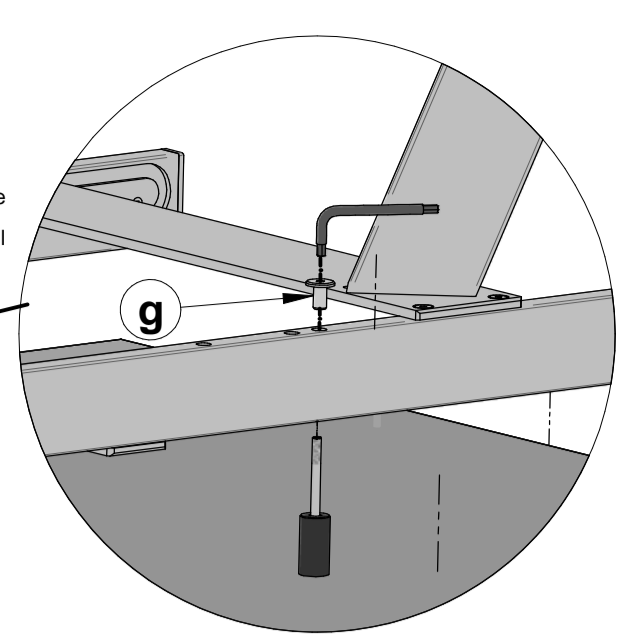

4

**Attenzione-Attention-Vorsicht-Attention-Atención**

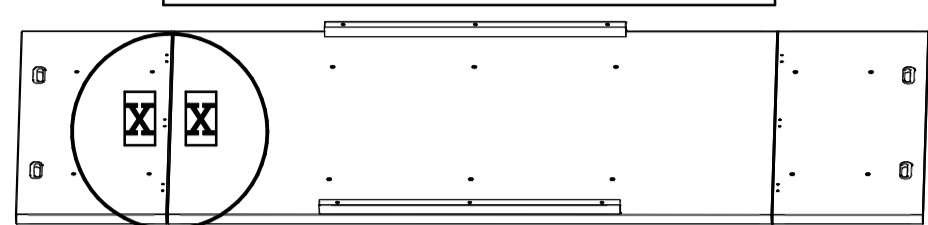

4a

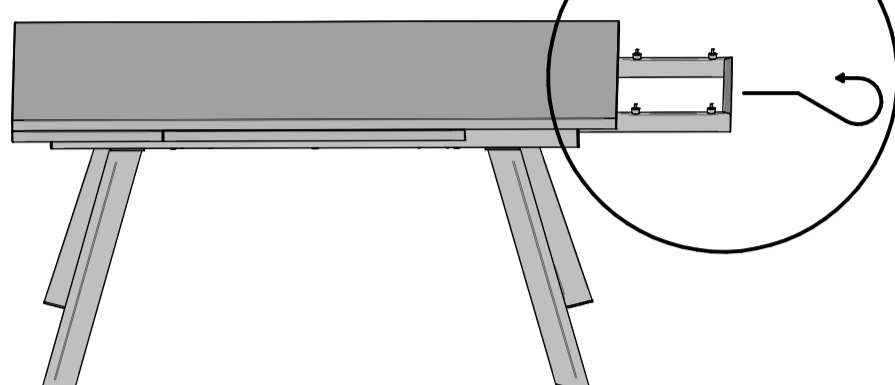

4b

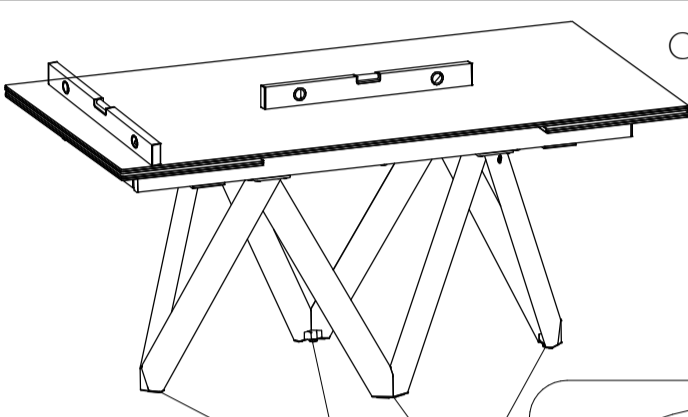
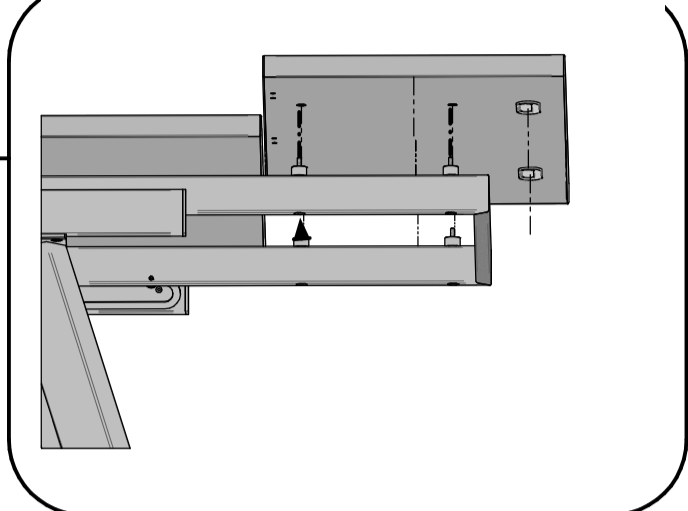

CS/4111

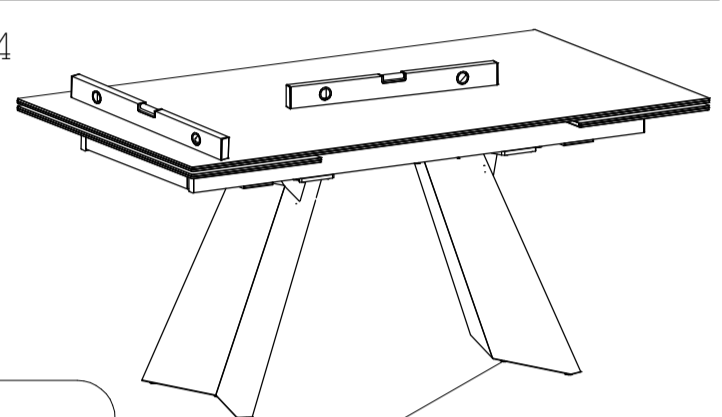

CS/4114

4c

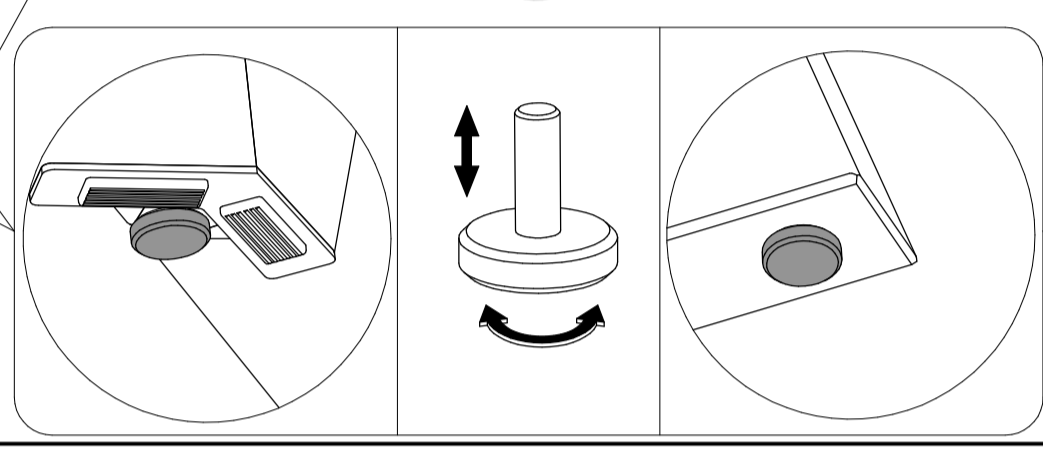

4d

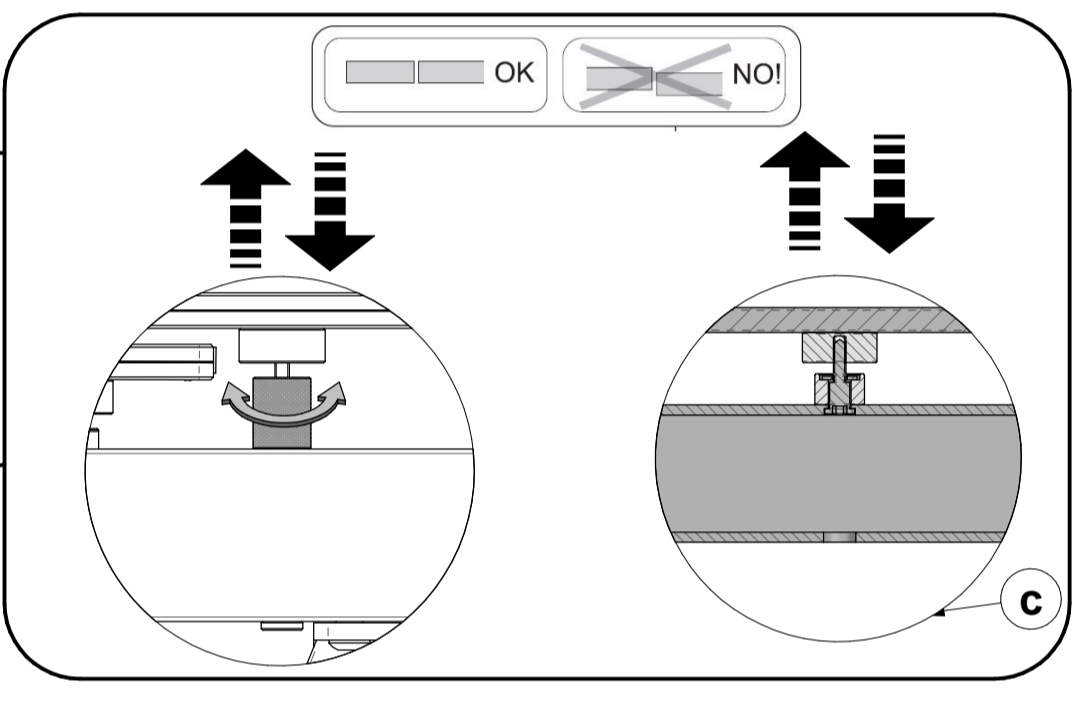
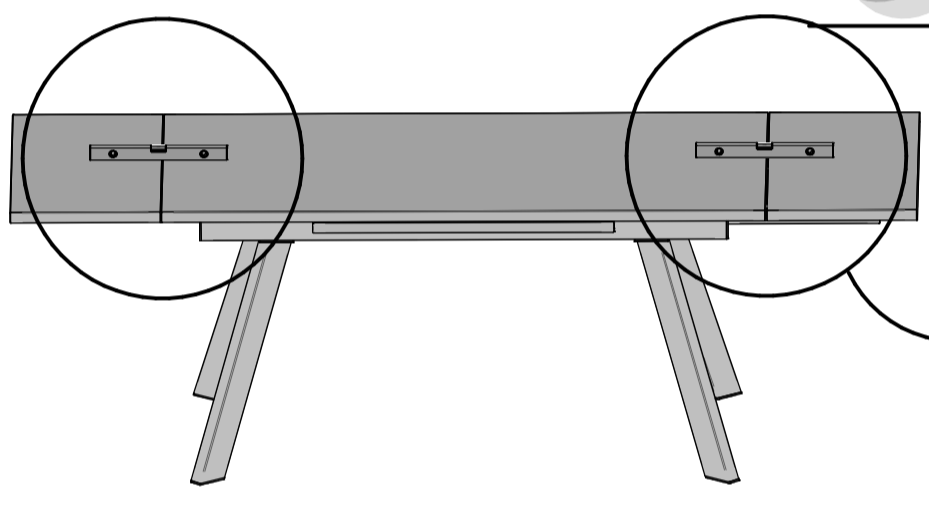

4e

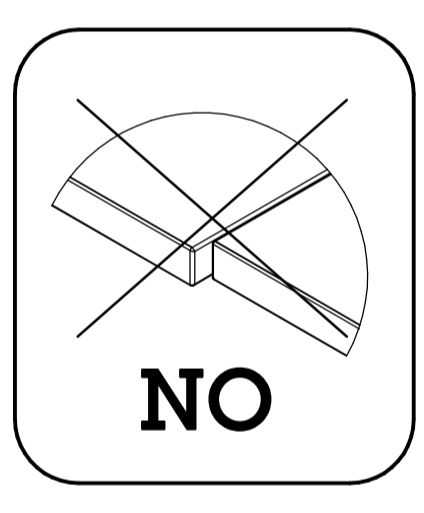
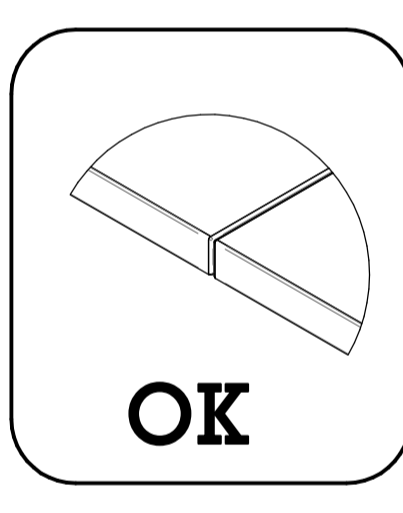
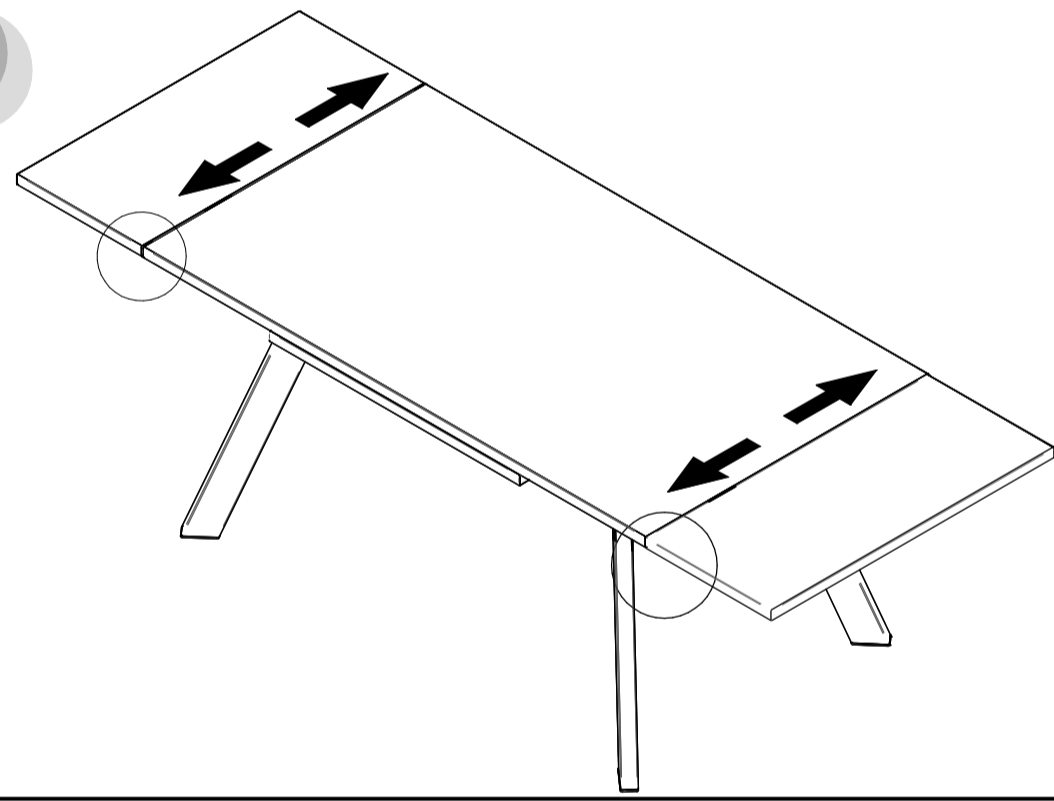

4f

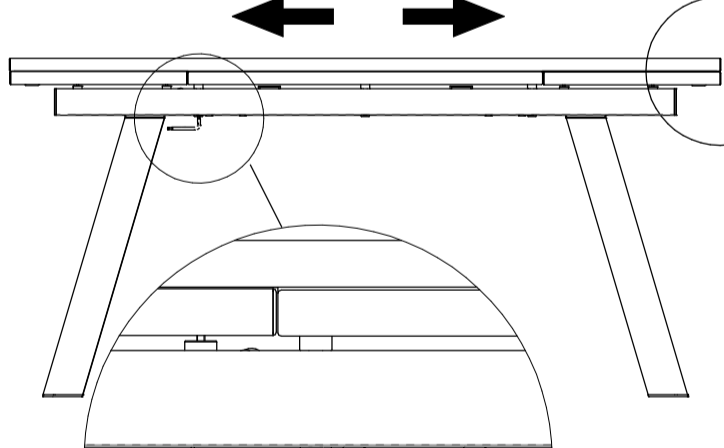

4g

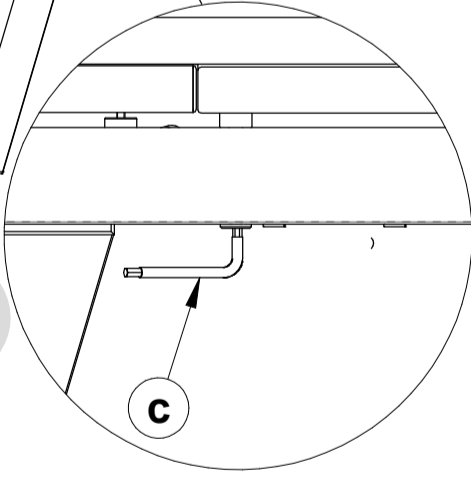

**Attenzione-Attention-Vorsicht-Attention-Atención**

- I Serrare a fondo le viti.
- GB Tighten the screws strongly.
- D Fest verschrauben.
- F Les vis doivent être serrées a fond.
- E Atornillar fijamente.

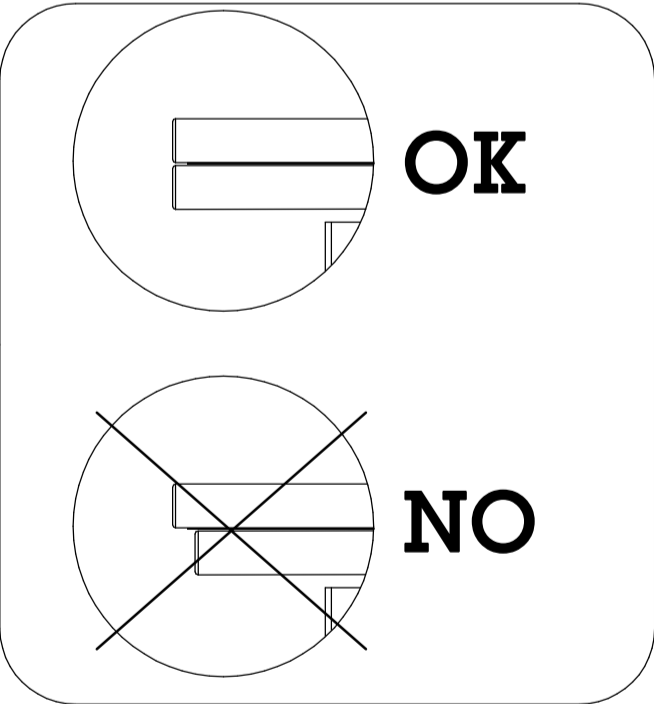

COMUNICAZIONI AL CLIENTE	CUSTOMER INFORMATION	MITTEILUNG AN DIE KUNDEN	COMMUNICATIONS AU CLIENT	COMUNICACIONES AL CLIENTE
<p>LA PRESENTE SCHEDA PRODOTTO DEVE ESSERE CONSEGNATA AL CLIENTE UNITAMENTE ALLA MERCE ACQUISTATA</p> <p><b>Tavolo ( Struttura ) : 'Ponente - Cartesio - Icaro'</b></p> <p><b>Modello: CS/4098 - CS/4111 - CS/4114</b></p> <p><b>Materiali</b> Struttura in metallo verniciato</p> <p><b>Istruzioni d'uso</b></p> <p>Per il montaggio fare riferimento alle relative istruzioni</p> <p>Al fine di garantire la stabilità e la durata nel tempo dell'articolo, si consiglia di verificare periodicamente il corretto serraggio delle viterie</p> <p>Il prodotto non è adatto ad uso esterno</p> <p>Non salire sul tavolo</p> <p>In caso di estensione del piano fare attenzione a non infrapporre le dita</p> <p>Il contatto delle superfici del prodotto con corpi caldi può danneggiare il materiale</p> <p>Per interventi di straordinaria manutenzione o di riparazione rivolgersi al rivenditore di fiducia</p> <p>Una volta dismessi il prodotto od i suoi componenti non vanno dispersi nell'ambiente, ma conferiti ai sistemi pubblici di smaltimento rifiuti</p> <p><b>Consigli di manutenzione</b></p> <p>I liquidi rovesciati devono essere assorbiti immediatamente con un panno pulito e asciutto</p> <p>Per la pulizia delle parti in metallo, utilizzare esclusivamente prodotti specifici</p> <p>Non usare prodotti abrasivi</p> <p>La Calligaris S.p.a. declina ogni responsabilità derivante da un uso improprio dell'oggetto sopra descritto</p>	<p>THIS PRODUCT LIST MUST BE DELIVERED TO THE CUSTOMER TOGETHER WITH THE PURCHASED MATERIAL</p> <p><b>Table ( Structure ) : 'Ponente - Cartesio - Icaro'</b></p> <p><b>Model: CS/4098 - CS/4111 - CS/4114</b></p> <p><b>Materials</b> Structure in lacquered metal</p> <p><b>User instructions</b></p> <p>Refer to the instructions for assembly</p> <p>In order to guarantee stability and life of the article, periodically check that the screws are correctly tightened</p> <p>The product is not suitable for outdoor use</p> <p>Do not climb on the table</p> <p>When extending the top, be careful not to trap fingers</p> <p>Contact with hot items can damage the surface</p> <p>For major maintenance or repairs, consult the retailer</p> <p>Once the product or its components are no longer used, make sure that they are disposed of correctly through the public waste disposal services</p> <p><b>Maintenance recommendations</b></p> <p>Any spills should be wiped up immediately with a clean, dry cloth</p> <p>To clean metal parts, use products that are specifically for metal</p> <p>Do not use abrasive products</p> <p>Calligaris S.p.a. disclaims any responsibility deriving from incorrect use of the above mentioned object</p>	<p>DIE VORLIEGENDE KARTE MIT DEN TECHNISCHEN DATEN DES PRODUKTS IST DEM KUNDEN ZUSAMMEN MIT DEM EINGEKkauFTEN PRODUKT ZU ÜBERGEBEN</p> <p><b>Tisch ( Gestell ) : 'Ponente - Cartesio - Icaro'</b></p> <p><b>Modell: CS/4098 - CS/4111 - CS/4114</b></p> <p><b>Materialien</b> Gestell aus lackiertem Metall</p> <p><b>Gebrauchsanweisung</b></p> <p>Zur Montage die entsprechende Gebrauchsanweisung konsultieren</p> <p>Zur Gewährleistung der Stabilität und der Beständigkeit des Artikels, ist die regelmäßige Prüfung der korrekten Schraubensicherung ratsam</p> <p>Das Produkt ist für die Außenanwendung nicht geeignet</p> <p>Steigen Sie nicht auf den Tisch</p> <p>Beim Ausziehen der Platte ist darauf zu achten, die Finger nicht einzuklemmen</p> <p>Um Schäden vorzubeugen, verhindern Sie bitte den Kontakt der Oberflächen mit heißen Gegenständen</p> <p>Wenden Sie sich für außerordentliche Wartungsarbeiten oder Reparaturen an den Händler Ihres Vertrauens</p> <p>Wenn das Produkt oder seine Komponenten keine Verwendung mehr findet, dann muß es entsprechend über öffentliche Müllsysteme entsorgt werden</p> <p><b>Wartungshinweise</b></p> <p>Verschüttete Flüssigkeiten müssen sofort mit einem sauberen und trockenen Tuch entfernt werden</p> <p>Verwenden Sie zur Reinigung der Metallteile ausschließlich Produkte, die speziell für Metall geeignet sind</p> <p>Benutzen Sie keine Schleifmittel</p> <p>Die Calligaris S.p.a. übernimmt keine Haftung bei unsachgemäßem Gebrauch des Produkts</p>	<p>LA FICHE PRODUIT DOIT ÊTRE REMISE AU CLIENT AVEC LA MARCHANDISE</p> <p><b>Table ( Structure ) : 'Ponente - Cartesio - Icaro'</b></p> <p><b>Modèle: CS/4098 - CS/4111 - CS/4114</b></p> <p><b>Matériaux</b> Structure en métal verni</p> <p><b>Instructions</b></p> <p>Pour l'assemblage voir les instructions</p> <p>Afin de garantir la stabilité et la durée de l'article il est conseillé de vérifier périodiquement le serrage des vis</p> <p>Le produit n'est pas prévu pour l'extérieur</p> <p>Ne pas monter sur la table</p> <p>Pendant la phase d'ouverture du plateau, faire très attention à ne pas se coincer les doigts</p> <p>Le contact de la surface du dessus avec des corps chauds peut endommager le matériel</p> <p>Pour toute intervention d'entretien extraordinaire ou de réparation, contacter le revendeur</p> <p>A la fin de son utilisation, le produit ou ses éléments ne doivent pas être abandonnés dans l'environnement, mais déposés auprès des centres de traitement et d'élimination des déchets</p> <p><b>Conseils d'entretien</b></p> <p>Les liquides renversés doivent être absorbés immédiatement avec un chiffon propre et sec</p> <p>Pour le nettoyage des parties en métal, utiliser exclusivement des produits spécifiques pour le métal</p> <p>Ne pas utiliser des produits abrasifs</p> <p>Calligaris S.p.a. décline toute responsabilité en cas d'utilisation inappropriée de l'objet indiqué ci-dessus</p>	<p>LA RCHA DE PRODUCTO DEBE ENVIARSE AL CLIENTE JUNTO A LA MERCANCIA</p> <p><b>Mesa ( Estructura ) : 'Ponente - Cartesio - Icaro'</b></p> <p><b>Modelo: CS/4098 - CS/4111 - CS/4114</b></p> <p><b>Materiales</b> Estructura en metal lacado</p> <p><b>Instrucciones de uso</b></p> <p>Para el montaje seguir las instrucciones al pie de la letra</p> <p>Al fin de garantizar la estabilidad y la duración en el tiempo del artículo, se aconseja controlar periódicamente que los tornillos sean correctamente apretados</p> <p>El producto no es apto para el uso en exteriores</p> <p>No subirse sobre la mesa</p> <p>Poner atención a los dedos al extender la mesa</p> <p>El contacto de la superficie del producto con cuerpos calientes puede degenerar el material</p> <p>En caso de reparaciones o de mantenimiento extraordinario dirigirse al comercio vendedor</p> <p>Cuando se deseché el producto utilizar los canales apropiados</p> <p><b>Consejos de mantenimiento</b></p> <p>Los líquidos derramados deben ser absorbidos inmediatamente con un paño limpio y seco</p> <p>Para la limpieza de las partes metálicas, utilizar exclusivamente productos específicos para el metal</p> <p>No usar productos abrasivos</p> <p>Calligaris S.p.a. declina toda responsabilidad en cas d'utilisacion inapropiada de los objetos arriba descritos</p>